

9. SPQ Series (Unshielded Type)

Applications

- High frequency communication products.
- DC/DC converters, etc.
- Other various electronic appliances.

Features

The miniature chip inductors is wound on a special ferrite core.
Ideal inductors for DC-DC conversion.



Inductance and Rated Current ranges

Part Series	Inductances range	Rated Current range
* SPQ1813	0.18~180μH	11.90~0.50A
* SPQ4920	0.47~100μH	25.10~1.80A

(Dimension data (Refer to Fig. 1))

Part Series	Inductances range	Rated Current range
* SPQ322515	1.00~100μH	1.00~0.10A
* SPQ322520	1.00~560μH	0.445~0.04A
* SPQ453226	1.00~2200μH	0.50~0.03A
* SPQ322515C	0.47~120μH	3.40~0.17A
* SPQ322520C	1.00~560μH	1.00~0.06A
* SPQ453226C	1.00~470μH	1.08~0.09A
* SPQ575047C	0.12~10000μH	6.00~0.05A

(Dimension data (Refer to Fig. 2))

Characteristics

Rated DC Current : The current when the inductance becomes 10% lower than its initial value.
 (For SPQ1813, 4920, 322515C series : the inductance becomes 30% lower than its initial value.)
 The current when the temperature of coil increases to T=20 . (Ta=25)
 (For SPQ1813, 4920, 322515C series : temperature of coil increases to T=40 . (Ta=25)

Operating temperature range: -40~+105

Test equipment:

L: HP4284A & HP4285A LCR meter

DCR Resistance: Milli-ohm meter or equivalent.

Electrical Specifications at 25 .

Part Numbering System

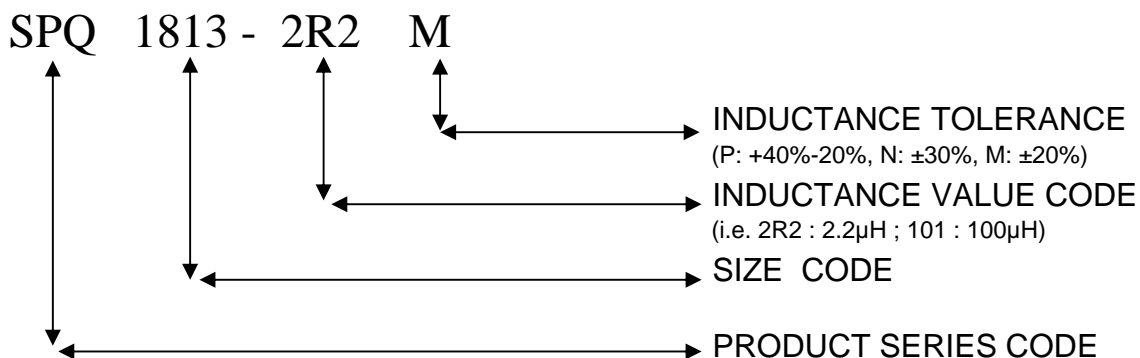

9. SPQ Series (Unshielded Type)

Dimensions (mm)

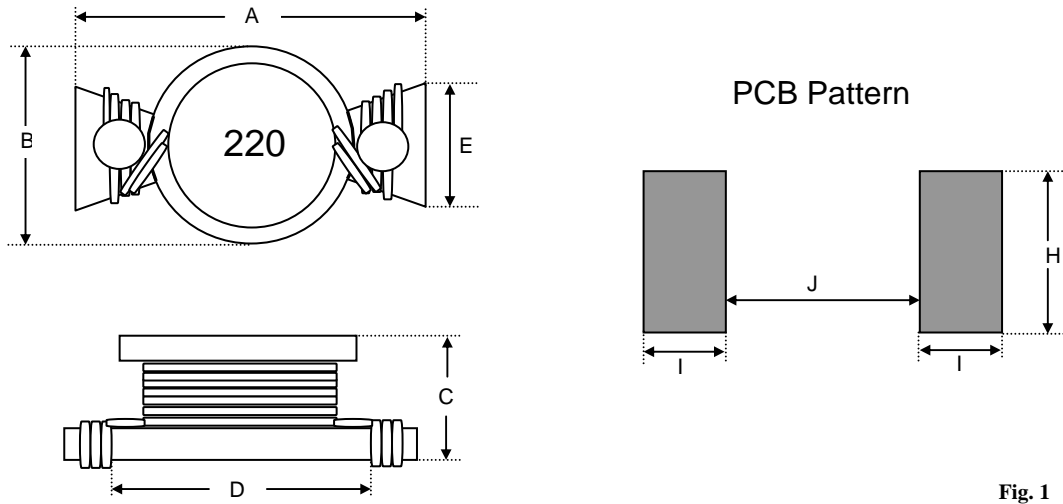

Fig. 1

Series	A max	B max	C max	D	E	H	I	J
SPQ1813	8.89	6.40	5.00	5.80	3.00	3.00	2.00	5.00
SPQ4920	19.40	13.30	6.80	12.70	6.60	8.00	3.80	11.70

9. SPQ Series (Unshielded Type)**Electrical Characteristics****SPQ 1813 / 4920 TYPE**

Inductance value code	Inductance (μH)	Tolerance		DCR (mΩ) Max.		Rated DC Current (A) Max.	
		SPQ1813	SPQ4920	SPQ1813	SPQ4920	SPQ1813	SPQ4920
R18	0.18	N	-	5.0	-	11.90	-
R33	0.33	N	-	7.0	-	11.70	-
R47	0.47	N	P	8.0	3.0	10.80	25.10
R50	0.50	M	-	9.0	-	8.00	-
R56	0.56	M	-	10.0	-	7.70	-
1R0	1.0	M	P	16.0	4.0	7.30	15.30
1R2	1.2	M	-	17.0	-	5.30	-
1R5	1.5	-	P	-	6.0	-	12.00
2R2	2.2	M	M	35.0	8.0	3.50	10.20
3R3	3.3	M	M	40.0	9.0	3.00	9.30
3R9	3.9	M	-	51.0	-	3.00	-
4R7	4.7	M	M	54.0	12.0	2.60	7.70
5R6	5.6	M	-	71.0	-	2.40	-
6R8	6.8	M	M	80.0	19.0	2.20	6.20
8R2	8.2	M	-	95.0	-	2.00	-
100	10	M	M	111.0	27.0	1.90	5.20
120	12	M	-	148.0	-	1.70	-
150	15	M	M	170.0	32.0	1.50	4.30
180	18	M	-	231.0	-	1.30	-
220	22	M	M	250.0	50.0	1.20	3.70
270	27	M	-	330.0	-	1.10	-
330	33	M	M	350.0	69.0	0.99	3.00
390	39	M	-	450.0	-	0.96	-
470	47	M	M	470.0	109.0	0.87	2.40
560	56	M	-	648.0	-	0.85	-
680	68	M	M	730.0	156.0	0.68	2.00
820	82	M	-	1000.0	-	0.81	-
101	100	M	M	1110.0	206.0	0.53	1.80
181	180	M	-	2300.0	-	0.50	-

1. Test Freq: 100KHz 0.1V

2. Rated DC current : The current when the inductance becomes 30% lower than its initial value. (Ta = 25 °C)

3. Operating temperature range: -40~+105